



And



**Have joined Forces to
to strengthen the Approach to the
North American Market
as**



- German family-owned enterprise in second generation, developed from technical engineers to an international supplier of automation technology for serial production.
- Tunkers shares the enthusiasm for technology with its worldwide staff of 800, never failing to strive for the better, more innovative solutions.
- Tunkers products are not commercial goods but “home-grown” products, invented, constructed produced and marketed by TUNKERS – always in a close dialogue with our customers, OEMs, plant engineers and engineering offices.
- A network with 10 subsidiaries and 20 partners support the sales organisation preliminary in those international markets where automobiles are manufactured.
- In the area of power clamps and indexing tables Tunkers is market leader in body assembly with the largest market being in Europe, South America and China.



Milestones of the Growth of the TÜNKERS Group



Milestones for the success

- Y 2003: Foundation TÜNKERS China
- Y 2004: Foundation TÜNKERS Czech
- Y 2006: Acquisition of EXPERT, Germany
 - Indexing Table and Conveying system
- Y 2010: Acquisition of SOPAP, France
 - Indexing Tables
- Y 2011: Acquisition of HELU, Germany
 - Welding guns
 - Acquisition Conveyer APM, Spain
 - Conveying system
- Y 2012: strategic alliance with Teamster, Sweden
 - Glueing systems
- Y 2013: Acquisition of Mastech, US
 - Conveying and systems technology

ALL ACQUISITIONS are focused on
TÜNKERS Core business
and the TÜNKERS VISION

Our Target is to position TÜNKERS as a world wide leading company for automation tools and systems in the area of robot automation in the automotive industry

TÜNKERS – We are worldwide



TÜNKERS Maschinenbau GmbH

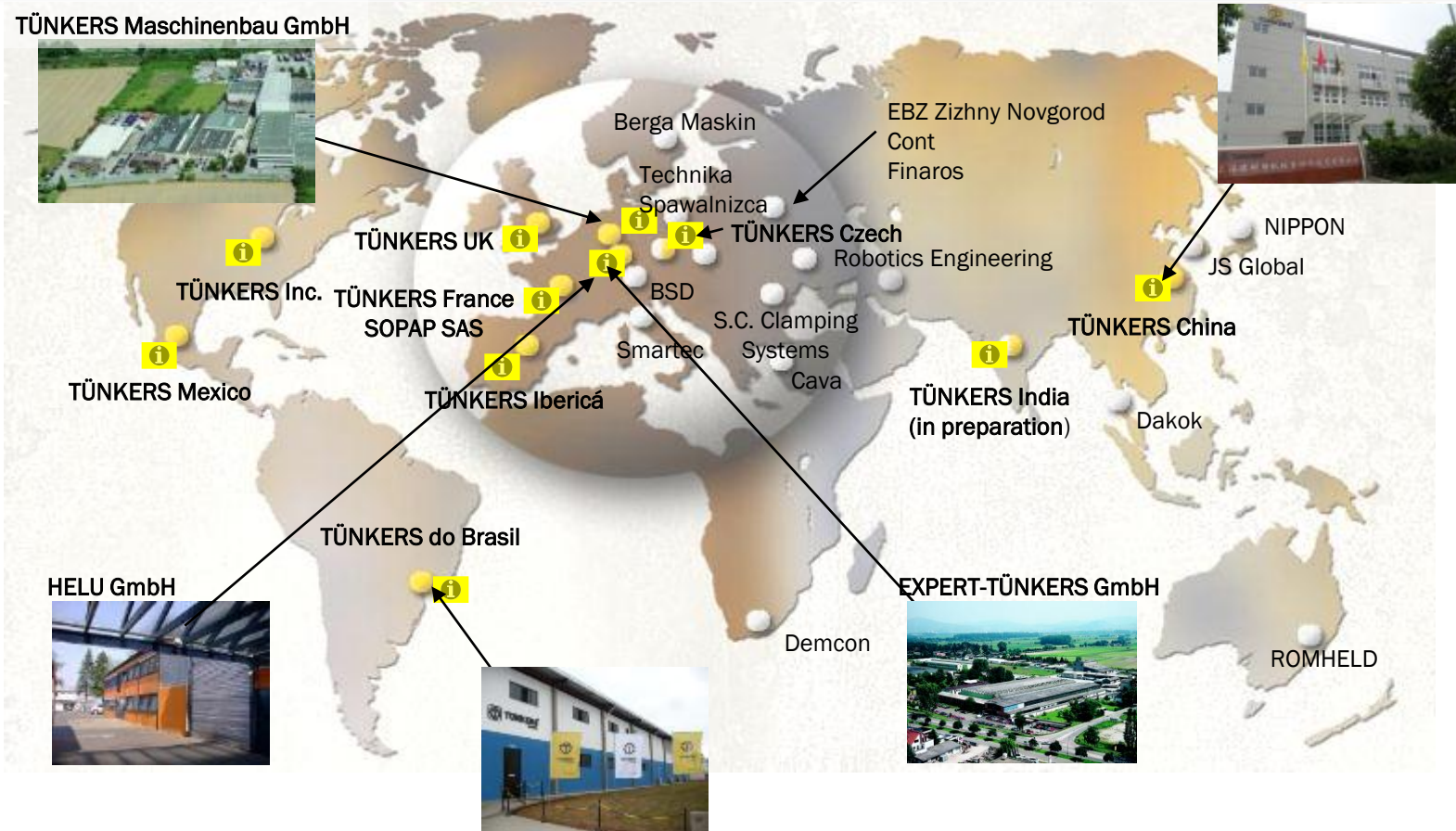

- Mastech is a **small domestic line builder** with a special focus on conveying applications.
- Mastech offers a **range of standard products** including belt- conveyers and rack systems.
- Mastech **was up to 2009 the exclusive sales partner of a German based conveyor specialist.**
- Mastech is since 2010 an **independent U.S. based producer of conveying and LCA solutions**
- Mastech **has products and application knowhow** not only in the area of body assembly but also **in the power train and press shop areas.**
- Mastech **is focusing itself on the US market with a capacity in development, design and production**
- Mastech has **excellent contacts within the US automotive industry** especially at Chrysler, Ford and GM along with other Tier One customers and line builders

- More than Clamps
 - Besides Power Clamps and Turn Tables TUNKERS-MASTECH offers the whole 9 Modules of Automation in the US-market now.

- From Distribution to full service
 - TUNKERS-MASTECH is a fully operating US Company with sales, service, production, design and development dedicated for the US and the Mexican market.
 - The MASTECH products like belt-, slat conveyors and rack system are now available through the TÜNKERS network worldwide.



TUNKERS-MASTECH Product Range



1. Power Clamps



2. Retract Pin Units
Double Piston Rod – with
Toggle lock function



3. Slides
pneumatic or electric driven



4. Power Pivots



5. Welding guns
Welding Power Clamps



6. Piercing units
here Shock Tower
Pierce units with manipulator

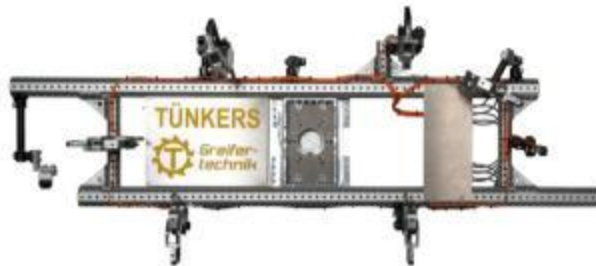

7. Modular Gripping systems

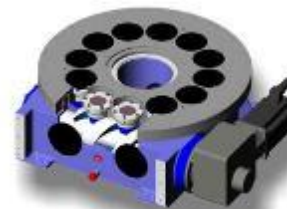

8. Indexing Turn Table



9. Lift and Shift System

... every day a new product idea – every week a new product



New
Electric Power Clamp



New
Modular Carbon Fiber Gripping System

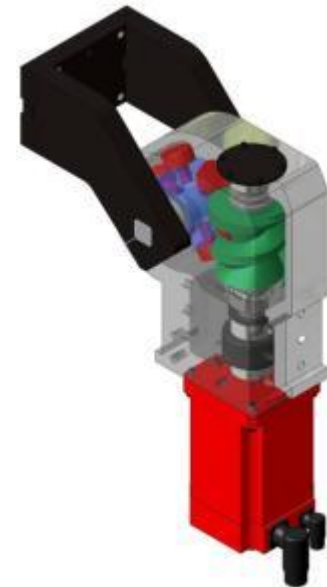

New
Servo Electric Power Pivot

TUNKERS-MASTECH Excellence in Conveying Solutions

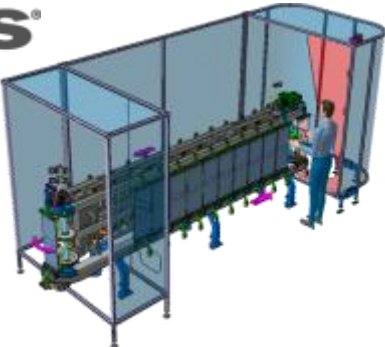

- Increased sales with an larger technical sales team to serve the North American market
- Improved service with design an installation capabilities
- Improved delivery time with increased US production
- Increased design capabilities in the US
- Extended product range
- Extended knowledge base

The TEAM up



GARY GAVIOLI
VP Finance/Operations
gg@tunkers.com

CHRISTIAN HEYER
VP Technology & Sales
c.heyer@tunkers.com

Brian Boothe
Sales Manager
brian.boothe@tunkers.com

Livonia Office
Components
Otterson Court
Office@tunkers.com

Sterling Heights
Systems&Conveyors
Wall Street
kelly.davis@tunkers.com