

Accumulating Belt Conveyor System LFS*

System LAT

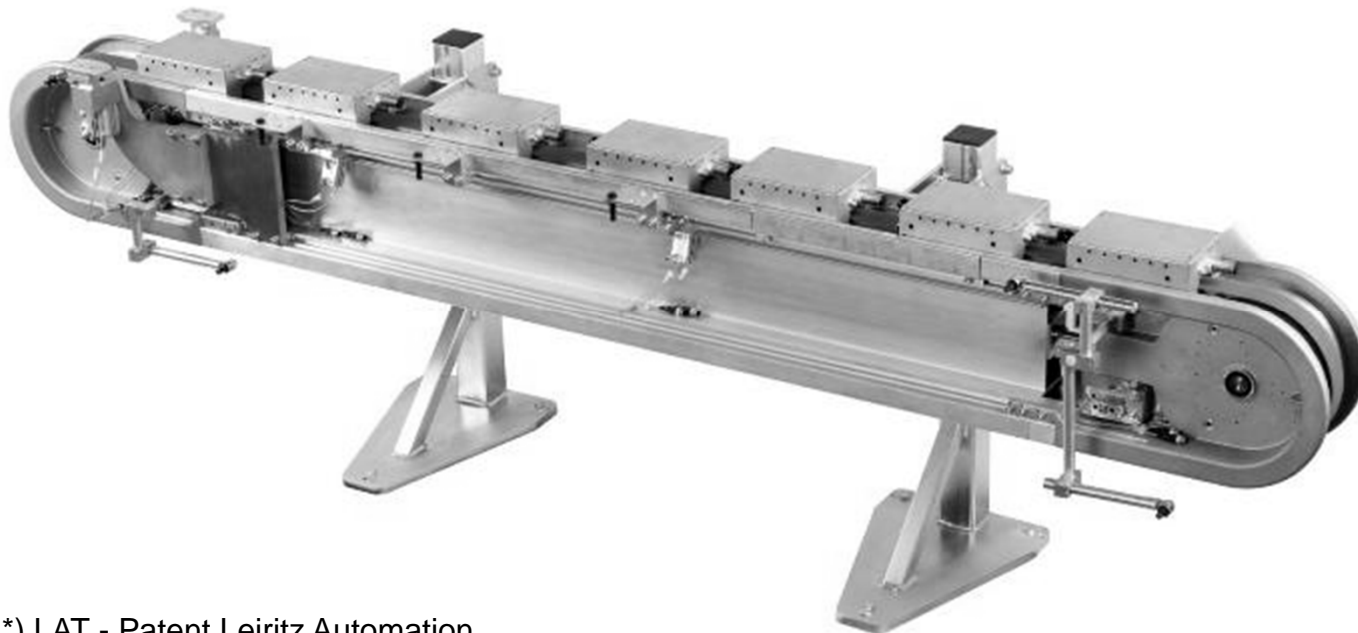

*) LAT - Patent Leiritz Automation

Accumulating conveyor transporting pallets not by a chain, but by a belt.

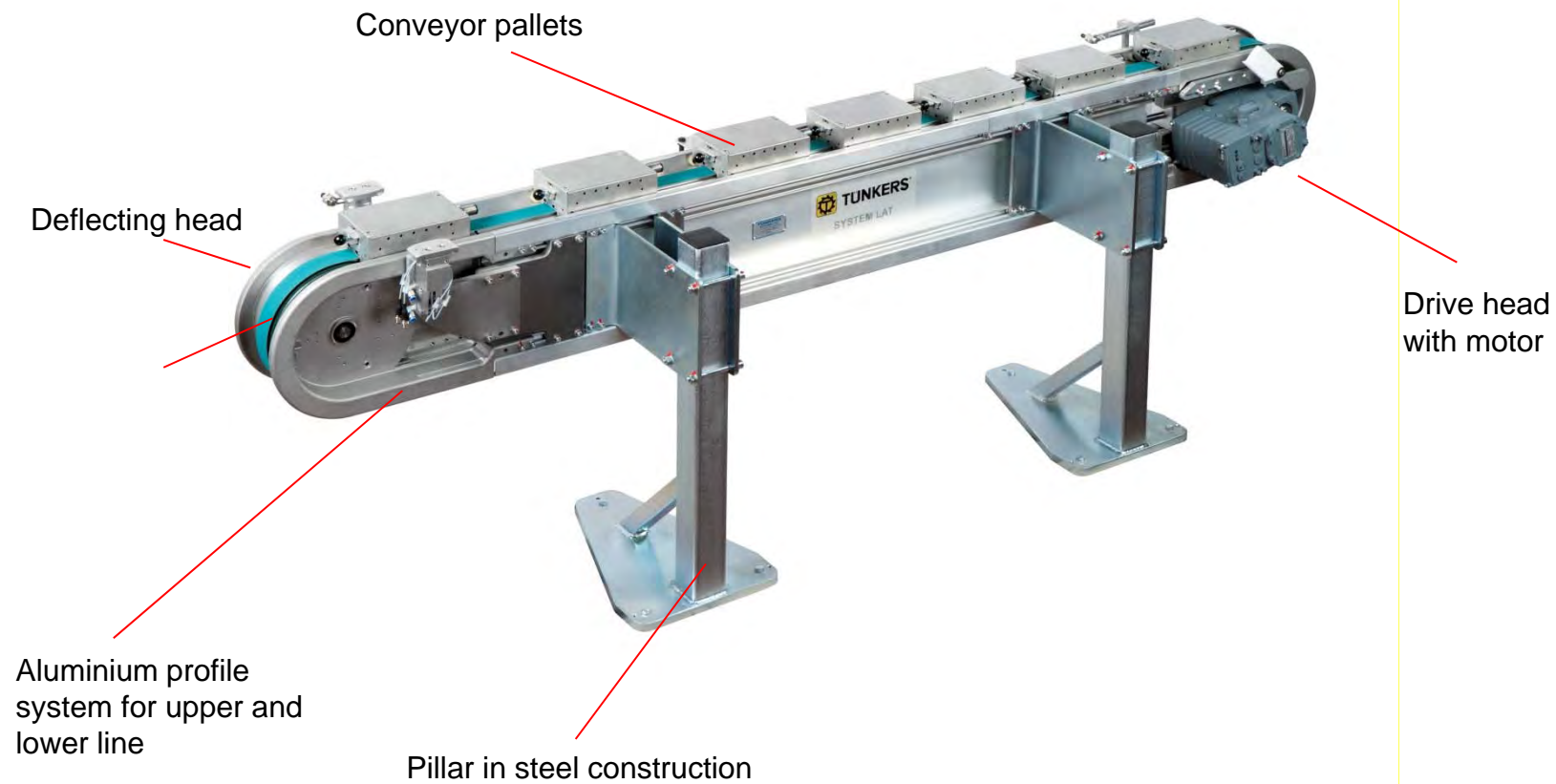

Operating principle:

- The pallet is jammed with the belt by a spring-preloaded mechanism.

Friction fit instead of form fit

- The clamping mechanism can be released by the release button.

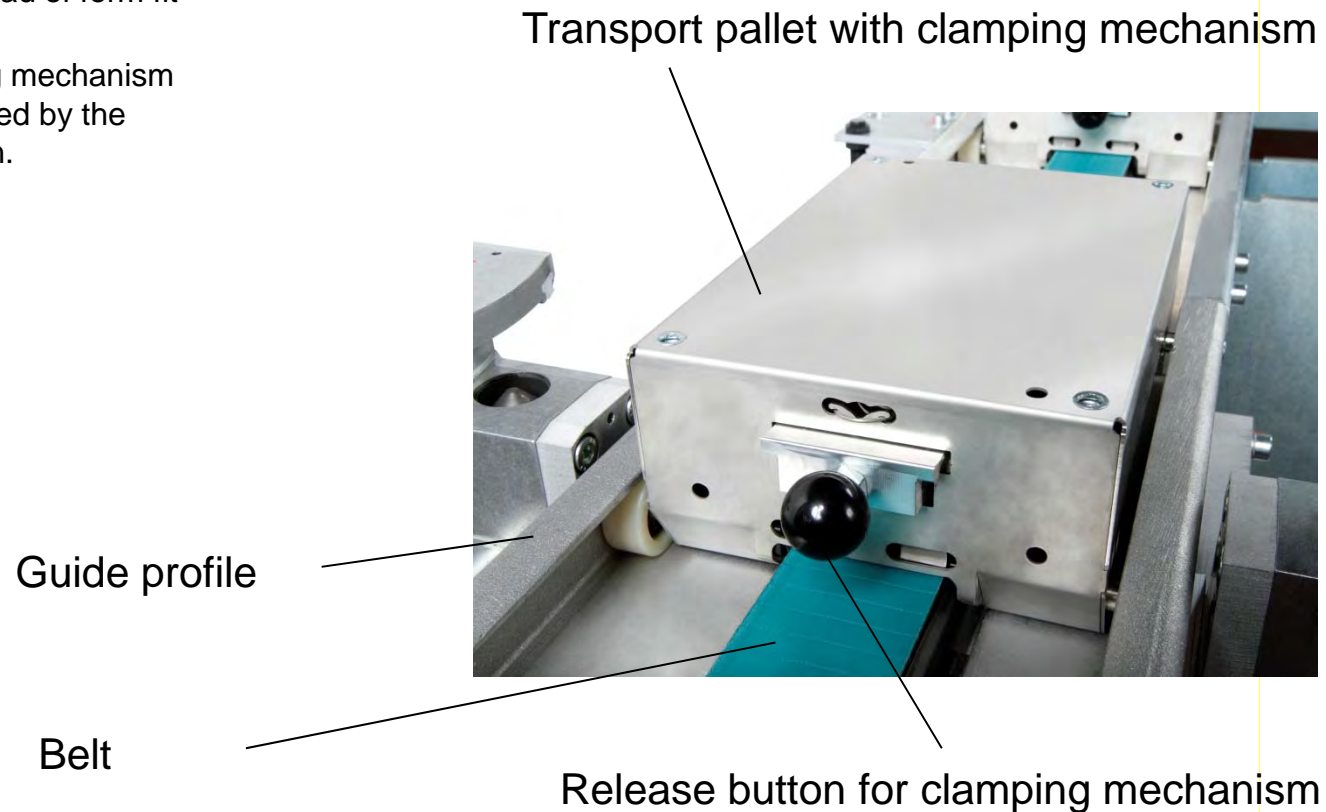

- During the accumulation of the pallets, the clamping mechanism of each previous pallet is released. Only the last pallet in the buffer area has a friction-fit connection with the belt conveyor.
- The engine output needs to be designed for the friction energy of only one pallet, even if several pallets are in the buffer area.

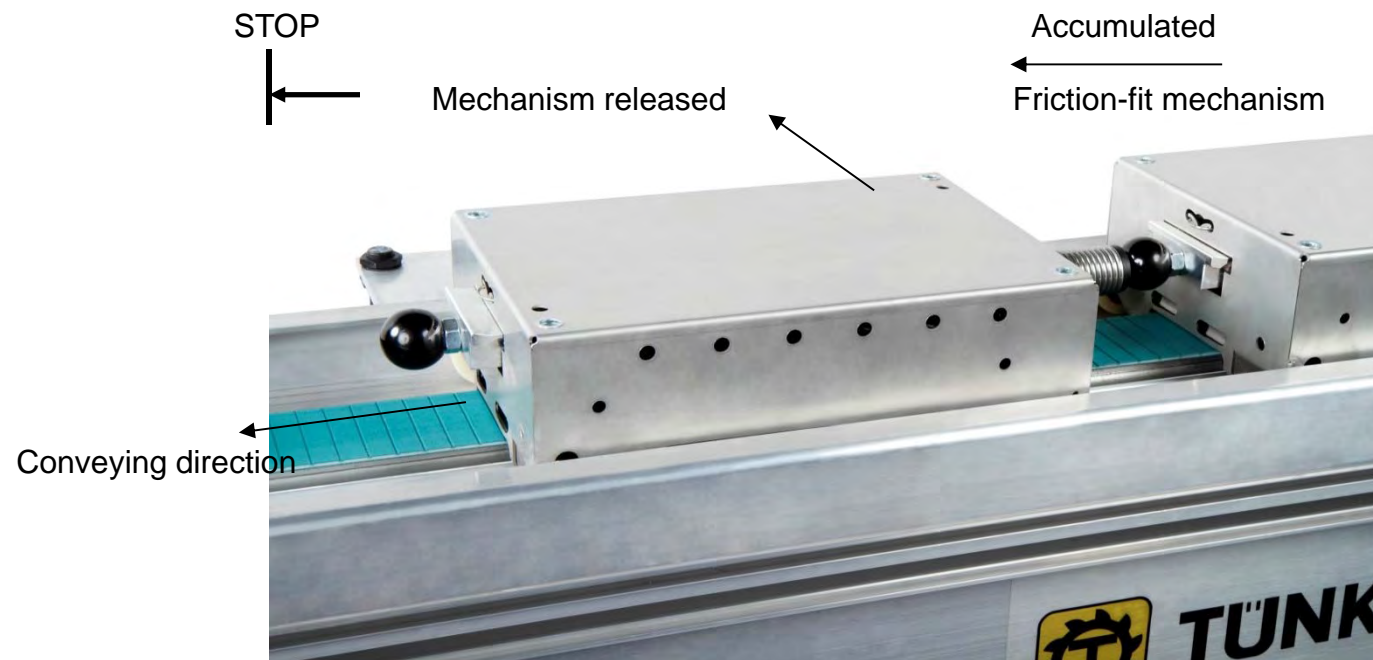

Detail Fine Positioning

Two ISO standard cylinders lift the pallet and secure the end position in x-y-z.



Advantages: Standard Operator Protection Based on Belt Principle

- In contrast to conventional accumulating conveyor belts, the pallet transport is provided by a belt \Rightarrow friction fit instead of form fit
- In the deflection the frictional locking is precisely adjusted to the pallet weight and the workpiece carrier weight.
- Therefore the operator can stop the pallet in any position.
- Special protective devices such as housing, light curtain or safety mats are not required.

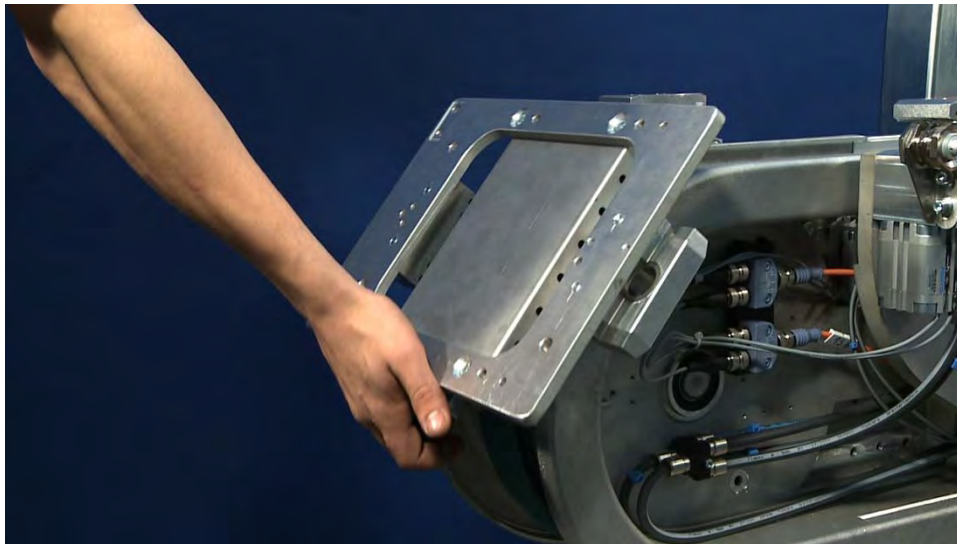

LFS-LAT Conveyor System

Advantages: Front Side Loading as safety enclosure is not required

- Lateral loading

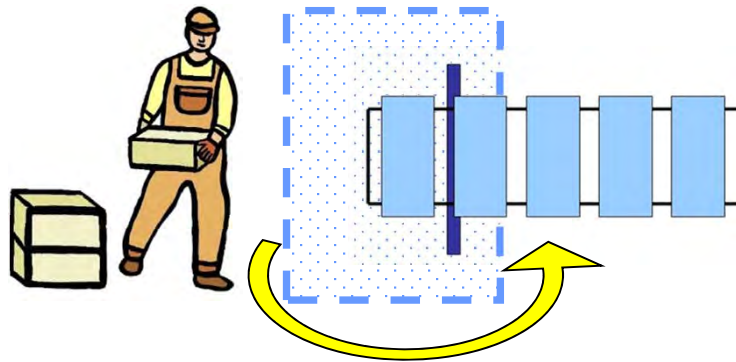

of conventional accumulating conveyor belts with high space requirements and loss of conveying length

- Front-side loading

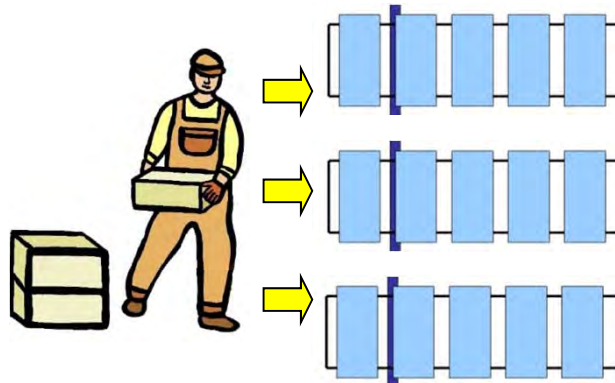

of TÜNKERS Belt Conveyors with space-saving arrangement in battery alignment

- **Conventional accumulating conveyor belt: energy destroyer!**
Each pallet is equipped with its own friction.
The engine output needs to be designed for the sum of the all pallet frictions accumulated in front of the stop stations.

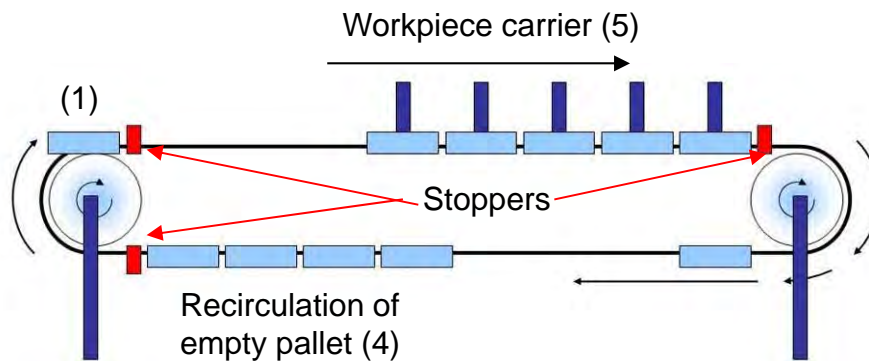

- In The TÜNKERS Belt Conveyor detaches the pallets from the belt during accumulation, only one pallet per stop station remains in friction-fit connection

- Motor design for
= 1 + 5 + 4 pallets
= 10 frictions
- Accumulation length limited to 10 pallets

- Motor design for 3 pallets
(approx. 150 N = Watt)
- No accumulation length limit

Characteristic features:

- Drive motor unchanged with 400 V three-phase AC technology
- All other actuators, stoppers / fine positioners in 24 V DC technology
- Central motor terminal TMI8 directly integrated in profile replaces valve island

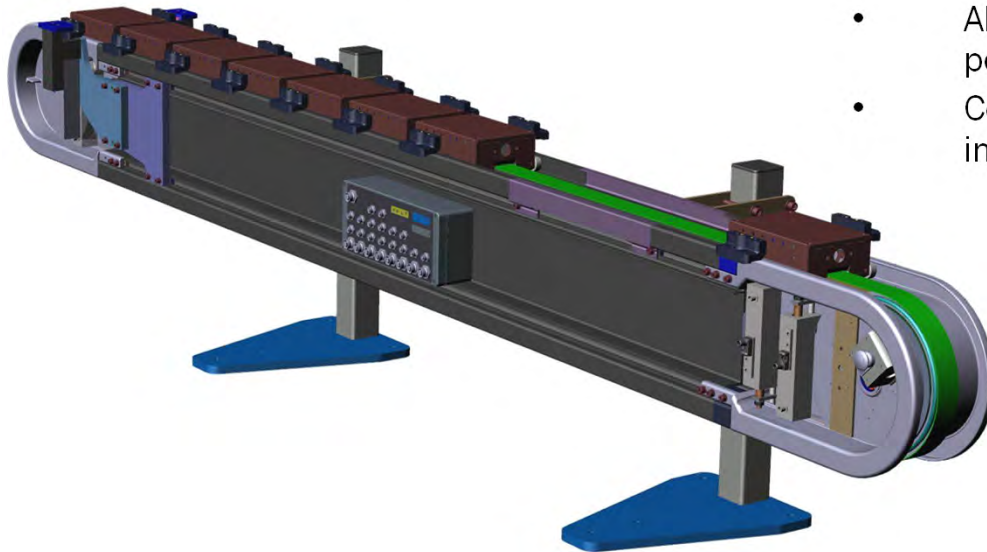

Motor terminal TMI8



Stopper for pallet with electric shot pins ESZK 30, 24 V

- Operator protection ensured in every position due to not required form fit between drive chain and pallet.
- Front-side loading and unloading are possible.
- No safety enclosure or special operator safety technology required.
- Space-saving arrangement of conveyor lines with front-side loading
- Minimum space requirement
- Low and always constant power requirement of the drive motor, as there is always a pallet in friction-fit connection with the belt conveyor.

Application Example 1

Multiple Line System with Front-side Loading



LFS-LAT Conveyor System

Application Example 2 Conveying of Pallets with Triple loading



LFS-LAT Conveyor System

Application Example 3 System with Transversely Arranged Pallets



LFS-LAT Conveyor System

Application Example 4 Conveying of Stacking Column Systems for Multiple Tool Mounting



LFS-LAT Conveyor System

Application Example 5 System with Transversely Arranged Pallets

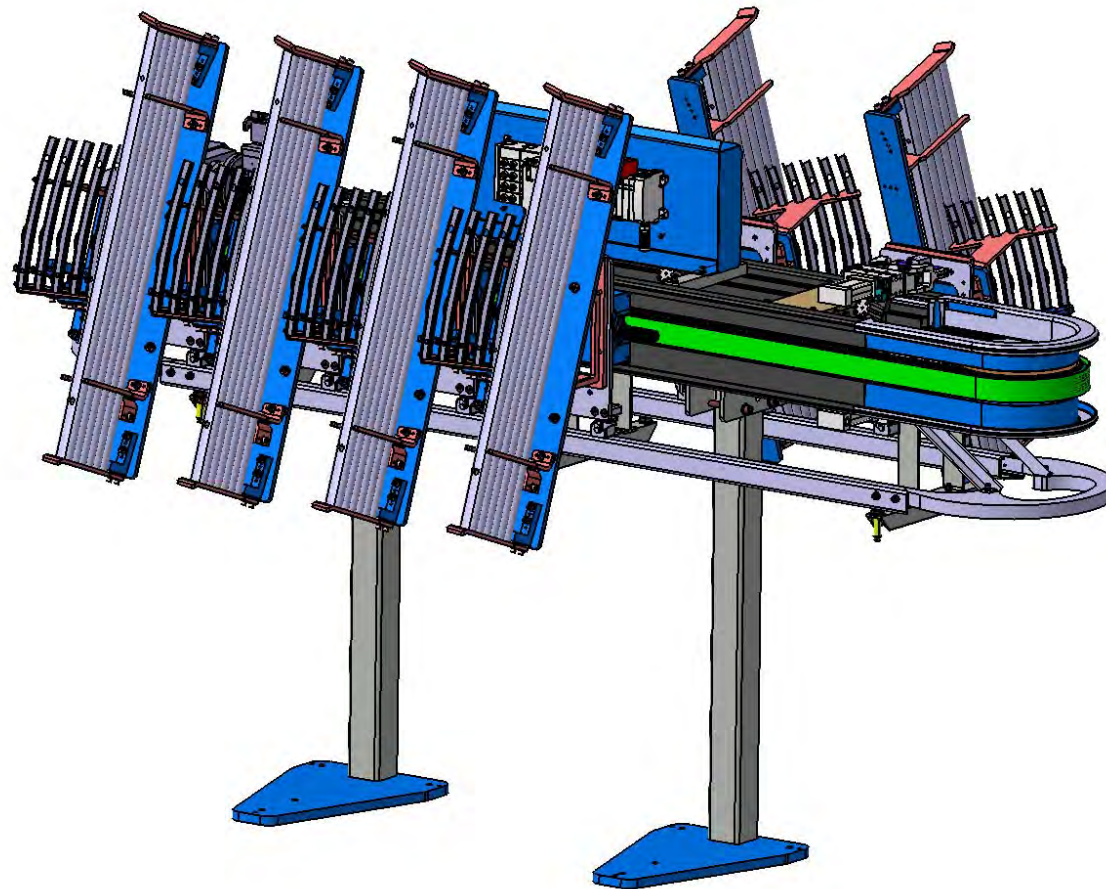

Application Example 6 Frontend Loading with Lateral Support



LFS-LAT Conveyor System

TÜNKERS Maschinenbau GmbH

Herr Kai Mönkediek

Am Rosenkothen 4-12

40880 Ratingen

Telefon +49 (0) 2102-45 17-0

Mobil +49 (0) 162-1311896

Telefax +49 (0) 2102-45 17-9999

E-Mail kai.moenkediek@tuenkers.de

Internet www.tuenkers.de