

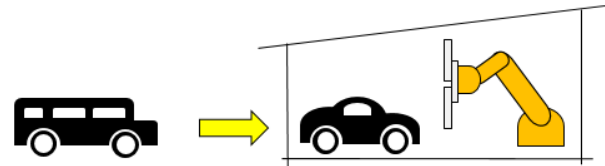

Carbon gripper systems from TÜNKERS
- Lightweight, robust, affordable -

- You want to integrate bigger, heavier models into existing systems without replacing the robot?



- You want to use a welding gun gripper combination with a robot?

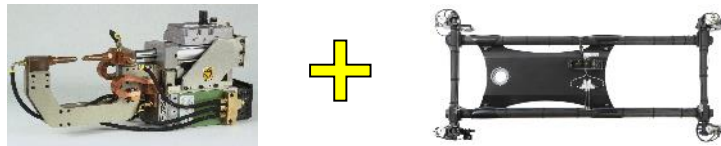

- You are looking for a lightweight and modular gripper system?

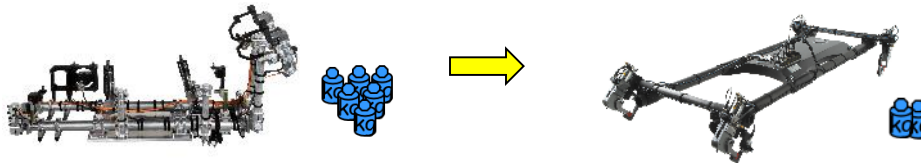

- You want to reduce energy consumption and cycle times?





Lightweight carbon tubes "GRC"
Ø 25/40/60 mm



Lightweight cross clips "GKC"

Lightweight carbon bracket „Stingray“

NEW



The modular system may be combined with the aluminium round tube system

Example of design structure

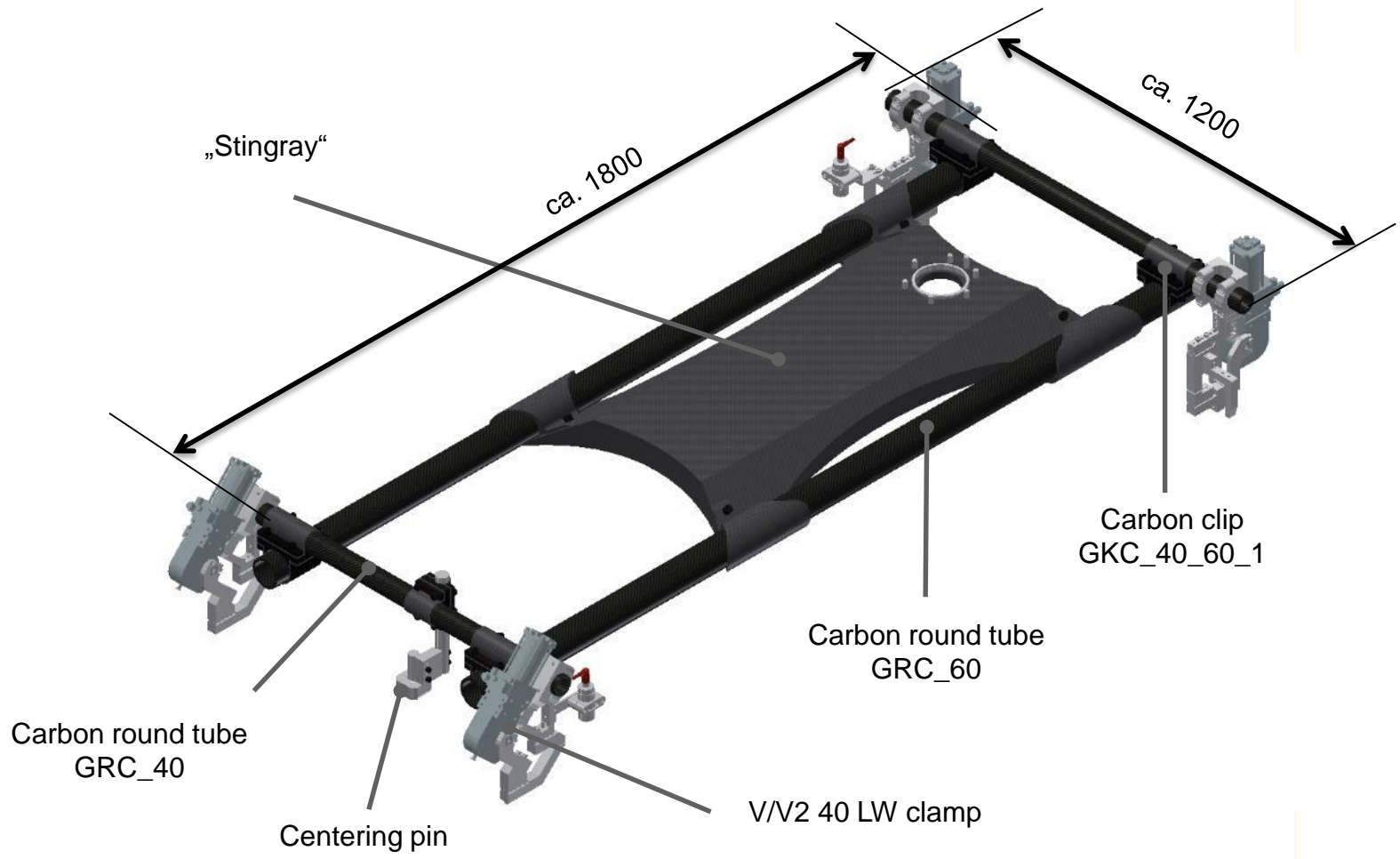

Stingray – The carbon lightweight bracket

- Weight 6 kg
- Integrated tube clips, robot connection and centering sleeves

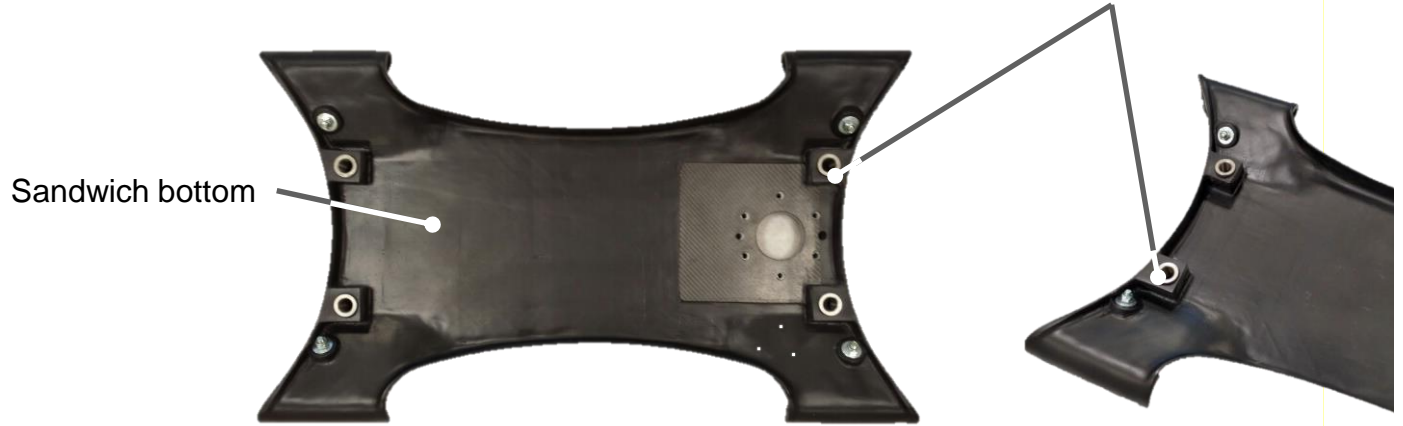

Weight of gripper system: ca. 30 kg (incl. E&P installation)

Component weight: ca. 115 kg

→ **Inversely proportional weight** compared to “usual” gripper applications!

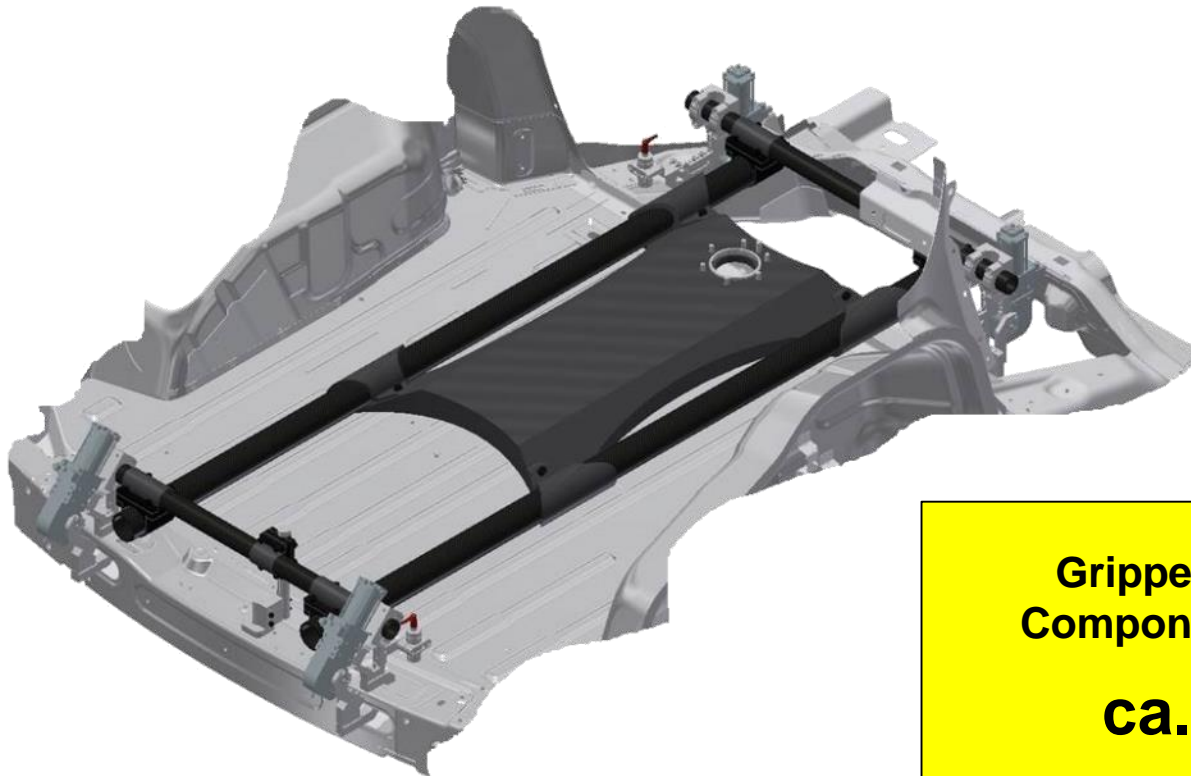

**Gripper weight/
Component weight**

ca. 1:4!

Detail views:



Example – modular hybrid gripper

Base frame – Aluminium

Connections – Carbon

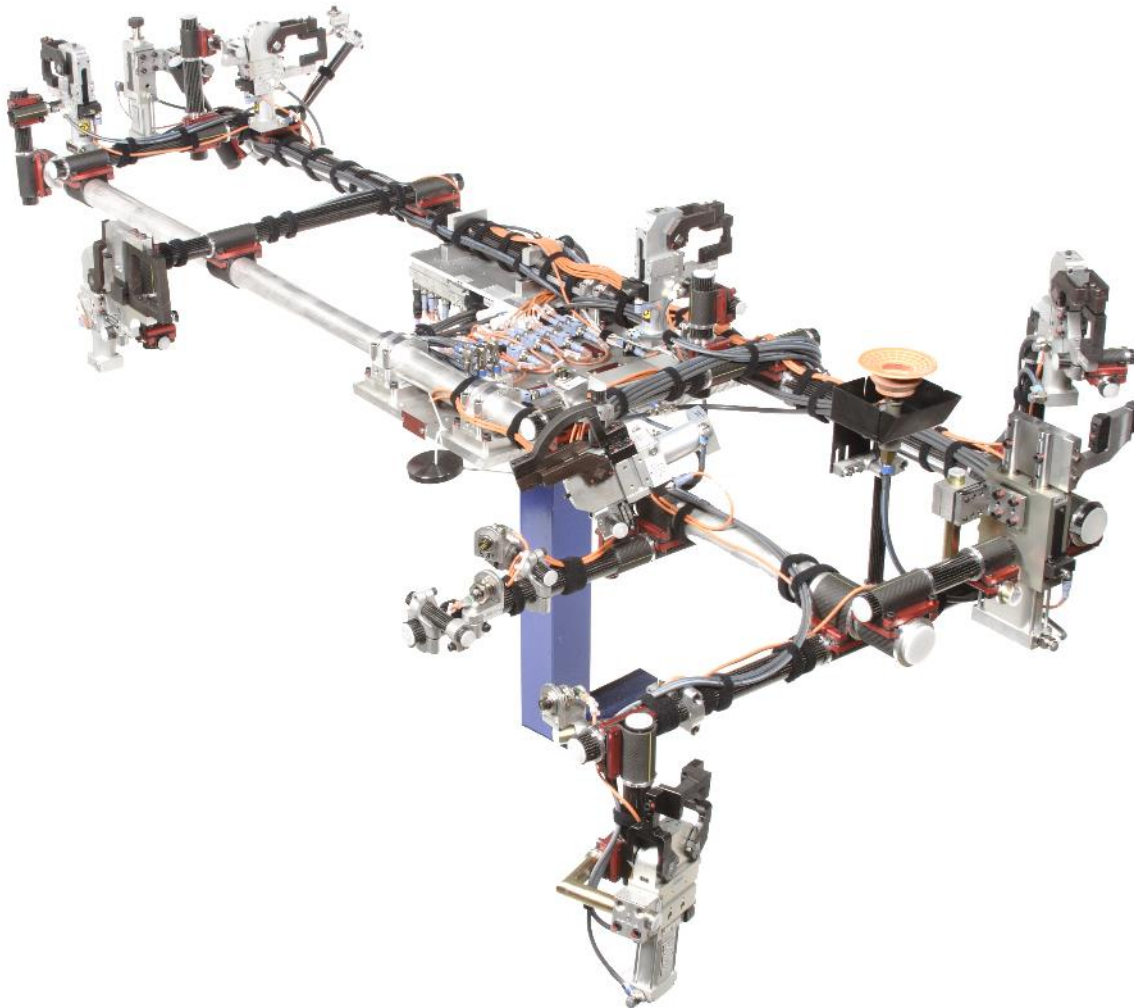

Example – Modular carbon gripper

Application: Transport of side panel

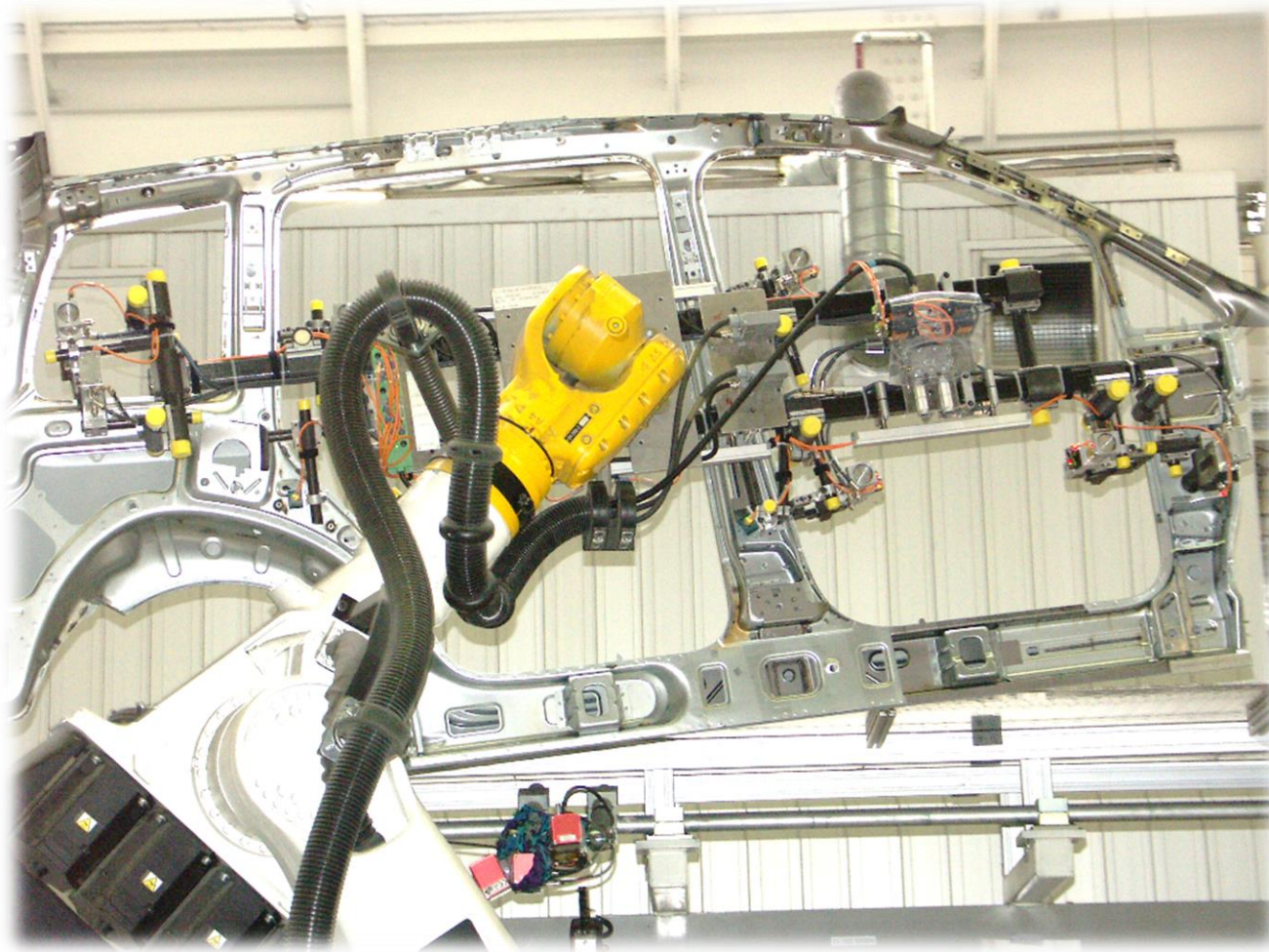

Additional costs for carbon gripper systems only arise for clip elements and tubes made from carbon fibre material. All other costs for clamps, valve island, E+P material, assembly, measurement and delivery remain unchanged.

→ **Additional cost** compared to the aluminium gripper system **ca. 20%***

Other benefits:

- No investment costs for the next higher robot class
- Lower process costs thanks to shorter cycle time and thus higher production volume
- Hybrid aluminium/carbon gripper systems may be used
- Wear and tear of robots is reduced for lower maintenance costs

* Individual components are more expensive

We will be pleased to advise you!

Contact:

Mr Matthias Heina

Product manager gripper technology

Phone +49 (0) 2102-45 17-282

E-Mail: matthias.heina@tuenkers.de

TÜNKERS Maschinenbau GmbH

Am Rosenkoth 4-12

D-40880 Ratingen

www.tuenkers.de

www.tuenkers-modular-automation.de

