

Unit for clamping and centering of tools

MCP 80

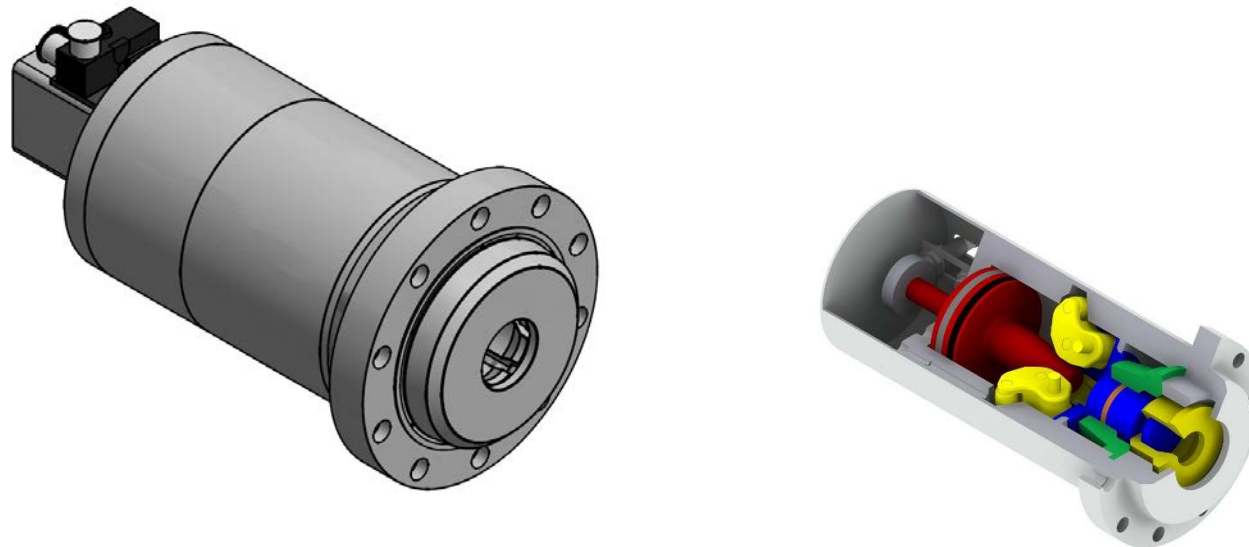

- The fact that a large number of variants are produced in a single plant results in an increasing number of tools and fixtures that have to be changed with short set-up times
 - The MCP 80 is a high-performance clamp-and-center unit which positions such tools and fixtures safely, fast and reproducibly
 - Examples include the precise coupling of side panel frames and change mechanisms in the framer stations
 - Features of MCP 80:
 - Clamping unit ready to be assembled
 - Pneumatic locking
 - Standard housing with threaded fastener for direct assembly
 - The clamped position is toggle-locked
- Centering, positioning, clamping, locking → only one unit

Overview MCP 80

- Two drive cylinders for more power
- To be integrated in existing 6bar compressed air network
- Separate air purge system

Zentrierung mit
Spannbacken
*Centering with
clamping jaws*

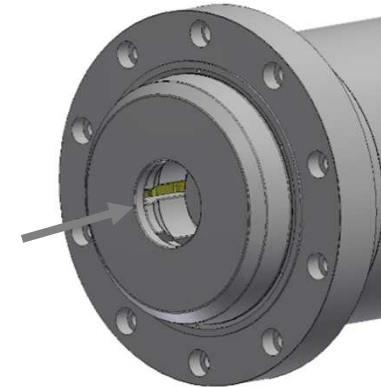

Rückseite mit Abfrage und
drei Luftanschlüssen
*Backside with switch and
three air connections*



Three clamping flange variants



Kegelspannflansch
Clamping flange



Zylinderspannflansch
Cylinder clamping flange



Segmentflansch
Segment flange

Clamping process

Basis: proven toggle wedge technology of the TÜNKERS multi-force cylinders

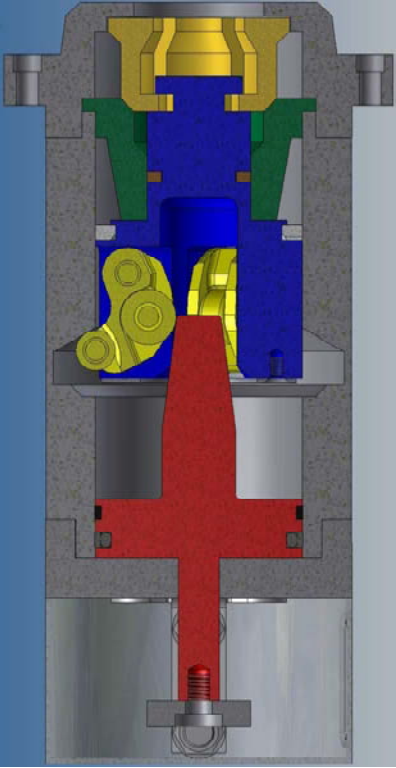

Open

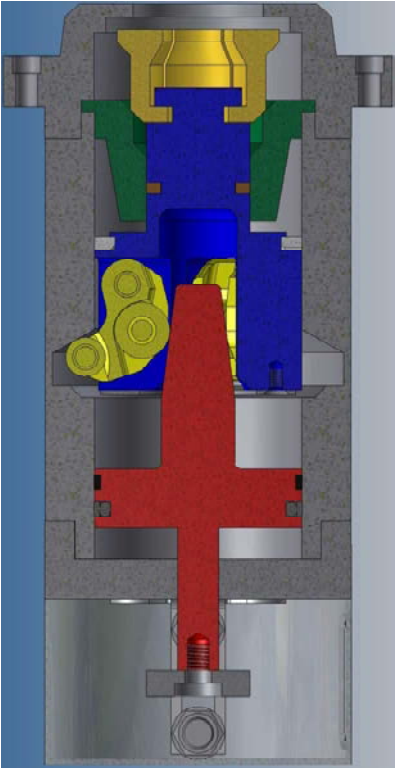

Close/Clamp

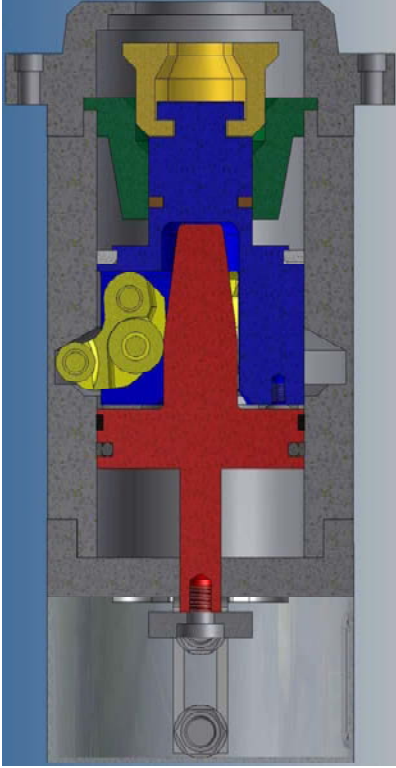

Lock

- Tool retainer: short taper 1:4, similar to DIN 55026 with plane support
- Integrated system monitoring
- Blast air cleaning
- Working stroke: 3 mm
- Retraction stroke: 3.5 mm
- Locking stroke: 3.5 mm
- Retraction force: 8.5 kN (6bar)
- Max. holding force: 40 kN (6bar)
- Radial offset when locking: ± 1.5 mm
- Angle offset when locking: 2°
- Flange play min.: 0.13 mm
- Flange play max.: 0.17 mm
- Endurance: 1,000,000

Force diagram

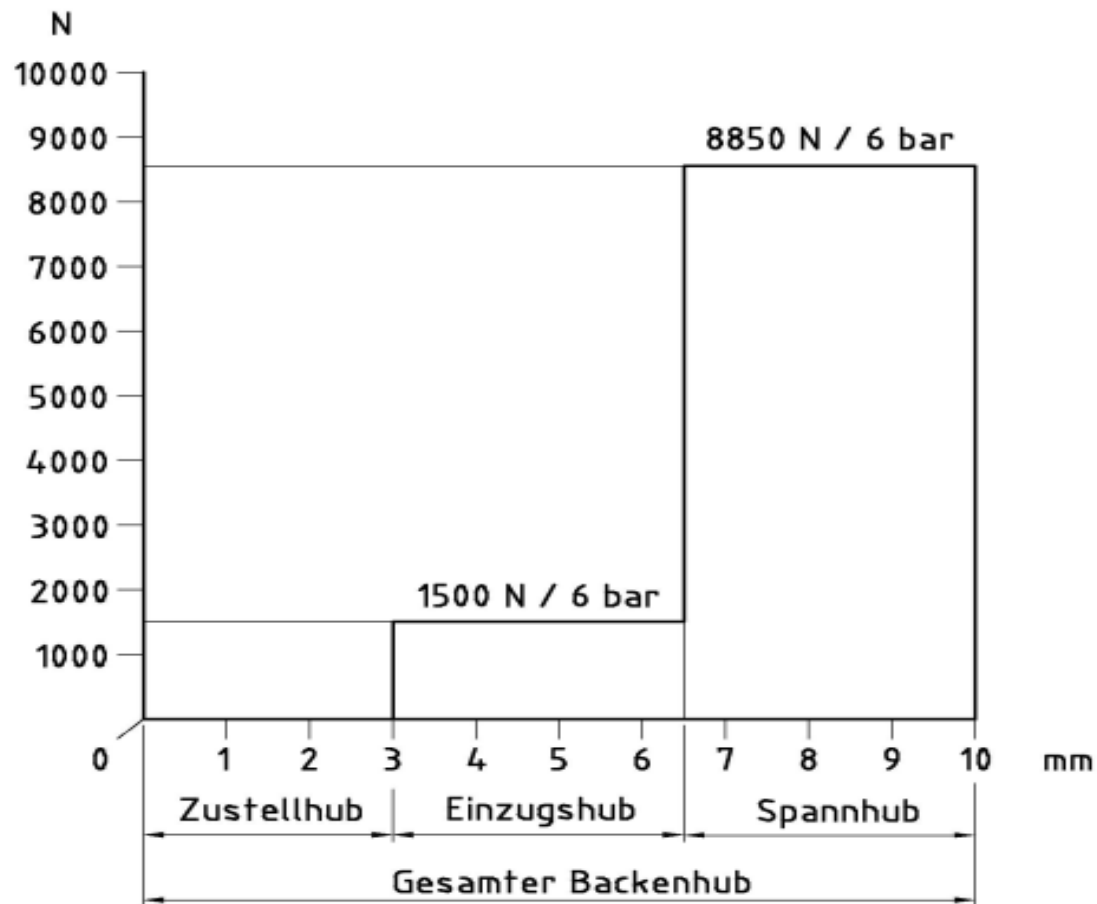

TÜNKERS Maschinenbau GmbH
Mr Christian Kleinschmidt
Am Rosenkothen 4-12
D-40880 Ratingen

Phone +49 (0) 2102-45 17-595
Fax +49 (0) 2102-45 17-9999

E-Mail christian.kleinschmidt@tuenkers.de
Internet www.tuenkers.de

YouTube 