

At your service - worldwide



TÜNKERS Maschinenbau GmbH
Am Rosenkoth 4-12
40880 Ratingen
Germany
Tel.: +49 2102 4517-0
info@tuenkers.de
www.tuenkers.de



EXPERT-TÜNKERS GmbH
Seehofstraße 56-58
64653 Lorsch
Germany
Tel.: +49 6251 592-0
info@expert-tuenkers.de
www.expert-tuenkers.de



HELU GmbH
Seehofstraße 56-58
64653 Lorsch
Germany
Tel.: +49 6251 592-280
info@helu.de



SOPAP Automation SAS
P. A. Ardennes Emeraude
Rue Henri Faure
BP 11 09, 08090 TOURNES
France
Tel.: +33 3 24 52 94 64
sopap@sopap.com

ARGENTINA – TÜNKERS DE ARGENTINA S.A.
Velez Sarsfield 1516 – Quilmes (1879)
Provincia de Buenos Aires
Tel.: +54 11 2100-2900
info@tuenkers.com.ar

AUSTRALIA – Romheld Australia Pty. Ltd.
30/115 Woodpark Rd
Smithfield N.S.W 2164
Tel.: +61 2 97211799
sales@romheld.com.au

AUSTRIA – B-S-D Spanntechnik GmbH
Sportplatzstrasse 31
3385 Markersdorf
Tel.: +43 2749 72870-0
office@bsdustria.com

BALTIC STATES – Vertriebsbüro Ost
Markt 11
D-07426 Königsee
Tel.: +49 36738 42432
dieter.rauschenbach@tuenkers.de

BELGIUM – SOPAP Automation SAS
P. A. Ardennes Emeraude
Rue Henri Faure
F-BP 11 09, 08090 TOURNES
Tel.: +33 3 24 52 94 64
sopap@sopap.com

BRAZIL – TüNKers do Brasil Ltda.
Avenida Casa Grande, 850 – Galpão 6, 11 e 13
Bairro: Casa grande
09961-350 – Diadema – São Paulo
Tel.: +55 11 4056-3100
comercial@tuenkers.com.br

CANADA – TUNKERS-Mastech
36200 Mound Road
Sterling Heights, MI 48312
Tel.: +1 734 744 5990
christian.heyer@tuenkers.com

CHINA – TÜNKERS China
Tuenkers Machinery & Automation
Technology Co., Ltd. Shanghai
Building 4, No. 768 Chenxiang Road,
Jiading District, Shanghai P.R.
China, 201802
Tel.: +86 21 39171070
info@tuenkers.com.cn
Other Offices: Changchun, Nanjing, Chengdu,
Beijing, Wuhan, Guangzhou, Yantai, Shenyang

CZECH REPUBLIC – Vertriebsbüro Ost
Markt 11
D-07426 Königsee
Tel.: +49 36738 42432
petr.cejka@tuenkers.sk

CZECH REPUBLIC – Kopta s. r. o.
Vážní 891 / areál PSN I
CZ-500 03 Hradec Králové
Tel.: +420 495 53 1210
kopta@kopta.cz

DENMARK – Berga Maskin
64693 Gnesta
Tel.: +46 158 31112
info@berga-maskin.se

FINLAND – Berga Maskin
64693 Gnesta
Tel.: +46 158 31112
info@berga-maskin.se

FRANCE – SOPAP Automation SAS
P. A. Ardennes Emeraude
Rue Henri Faure
BP 11 09, 08090 TOURNES
Tel.: +33 3 24 52 94 64
sopap@sopap.com

HUNGARY – TÜNKERS Slovakia s.r.o.
Roentgenova 26
SK85101 Bratislava
Tel.: +421 905 564 691
juraj.rampasek@tuenkers.sk

INDIA – TÜNKERS Automation India Private Ltd.
402 Supreme Head Quarters 36
Mumbai-Pune Bypass
411008 Baner-Pune
Tel.: +91 98 60 699190
jayesh.keskar@tuenkers.com

INDONESIA – DAB Technology Pte. Ltd.
21 Woodlands Industrial Park E1, #03-04
Singapore 757720
Tel.: +65 6891 3286
sales@dabtechn.net

ITALY – TÜNKERS Italia
Strada TORINO, 43 EUROPLACE sub. 06
10043 ORBASSANO-TORINO
Tel.: +39 011 6471556
s.tosco@tuenkers.it

JAPAN – TÜNKERS Japan Ltd.
Daimyo Create Bldg. 6F
Daimyo 1-8-20
Chuo-ku, Fukuoka 810-0041 JAPAN
Tel.: +81 80 83544786
tomoo.kaku@tuenkers.de

MALAYSIA – DAB Technology Sdn.Bhd.
No 9-2B Jalan Bandar 10, Pusat Bandar Puchong
47100 Selangor
Tel.: +603 8060 9448
sales@dabtechn.net

MOROCCO – SOPAP Automation SAS
P. A. Ardennes Emeraude
Rue Henri Faure
F-BP 11 09, 08090 TOURNES
Tel.: +33 3 24 52 94 64
michel.andre@tuenkers.de

MEXICO – TUNKERS DE MÉXICO S.A. DE C.V.
Prolongación Uranga No. 93 C
Colonia Sanctorum, Cuautlancingo
Puebla, C.P. 72730
Tel.: +52 222 393 5547
christian.volkmann@tuenkers.mx

NETHERLANDS – TÜNKERS Maschinenbau GmbH
Am Rosenkoth 4-12
D-40880 Ratingen
Tel.: +49 2102 4517-0
peter.czajkowski@tuenkers.de

POLAND – TÜNKERS Slovakia s.r.o.
Roentgenova 26
SK85101 Bratislava
Tel.: +48 660 055 225
jaroslaw.rozmiarek@tuenkers.sk
www.tuenkers.sk

ROMANIA – TÜNKERS Maschinenbau GmbH
55068 Sibiu, Romania
Tel.: +40-752 184 548
traian.moga@tuenkers.sk

RUSSIA – WEST-RU
Novikova-Priboya Str. 4 office 407
603058 Nizhny Novgorod
Tel.: +7 831 253 01 65

RUSSIA – Cont Group
Office 315, Sibirskij Proezd 2-27
Moscow 109316
Tel.: +7 495 775 - 0377

SERBIA – TÜNKERS Maschinenbau GmbH
55068 Sibiu, Romania
Tel.: +40-752 184 548
traian.moga@tuenkers.sk

SINGAPORE – DAB Technology Pte. Ltd.
21 Woodlands Industrial Park E1
#03-04
Singapore 757720
Tel.: +65 68913286
enquiry@dabtech.net

SLOVAKIA – TÜNKERS Slovakia s.r.o.
Twin City C
Mlynské nivy 16
SK82109 Bratislava
Tel.: +421 905 564 691
juraj.rampasek@tuenkers.sk
www.tuenkers.sk

SLOVENIA – TÜNKERS Maschinenbau GmbH
55068 Sibiu, Romania
Tel.: +40-752 184 548
traian.moga@tuenkers.sk

SOUTH AFRICA – Demcon (Cape) cc
PO Box 15237
ZA-60110 Emerald Hill/Port Elizabeth
Tel.: +27 41 4847411
demcon@demcon.co.za

SOUTH KOREA – JC Systems Co. Ltd.
#405 Ace Highend 9Cha, 233,
Gasan digital 1-ro, Geumcheon-gu, Seoul
Tel.: +82 70 7012089
j3cho@chol.com

SPAIN – TÜNKERS IBÉRICA, S.L.
c/ Enric Prat de la Riba, 14b
08830 Sant Boi de Llobregat (Barcelona)
Tel.: +34 93 3952827
tuenkers@tuenkersiberica.com

SWEDEN – BERGA MASKIN
SE-646 93 GNESTA
Tel.: +46 158 311 12
info@berga-maskin.se

THAILAND – DAB Technology Co., Ltd.
H20 424/15 Kanchanapisek Rd.
Dokmai, Pravat,
Bangkok 10250
Tel.: +66 97 072 8972
rodchaya.jaranyanont@tuenkers.de

TURKEY – Cava Makina
Imes Sanayi Sitesi E 503
34776 Umraniye / Istanbul
Tel.: +90 216 3809280
alp.varna@cava.com.tr

UK – TÜNKERS-EXPERT UK Ltd.
Unit 5, Ham Lane,
Kingswinford,
West Midlands.
DY6 7JR
Tel.: +44 (0) 1384 287690
neal.judge@tuenkers.de

USA – TUNKERS-Mastech
36200 Mound Road
Sterling Heights, MI 48312
Tel.: +1 734 744 5990
christian.heyer@tuenkers.com

VIETNAM – DAB Technology Pte. Ltd.
21 Woodlands Industrial Park E1
#03-04
Singapore 757720
Tel.: +65 68913286
enquiry@dabtech.net

TURNING



TURNING

Turning is a standard process in automation lines. To be precise, this involves stepwise turning and positioning in installations. In a typical application, rotary indexing tables move work pieces into a robot cell by a 180° movement. The positioning of circularly arranged work sequences into the production cell is another example of the use of

rotary tables. Requirements for rotary tables are high acceleration and braking processes as well as precise positioning in the work positions in the dwell period. The product ranges of Expert-Tünkers and SOPAP include standard rotary tables with performance data of max. 150.000 Nm with

dimensions of max. Ø 10 m. All systems are designed for highest process reliability and therefore suitable for use in high-volume machines. Taking into consideration design and size, we distinguish between the following systems:

CAM-DRIVEN ROTARY TABLES

Rotary indexing tables, where the torque of the geared motor is transmitted via a barrel cam and track rollers to the rotary table. Depending on the drive system, a distinction is made between rotary tables with fixed and flexible indexing.

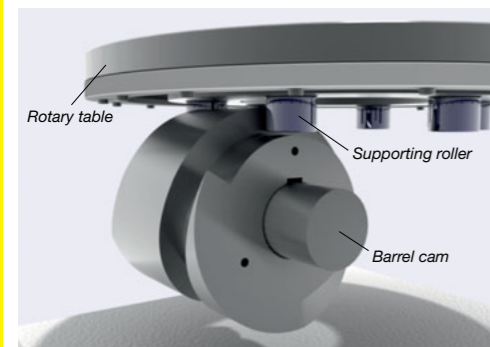

Construction principle cam-driven rotary table

Rotary tables with fixed indexing

Precision index drives for rotary movements transposing the motion profile with acceleration, braking and the required rotation angle scale over a form-closed barrel cam.

Conventional three-phase motors with constant revolution speed are used. These rotary tables are suitable for horizontal and vertical operation, for instance, in the form of trunnion drives.



High-precision fit in working position due to barrel cam profile principle

The table plate of rotary tables with fixed indexing is driven by two bolts. In the neutral position, they are moved to a broadened cam profil, thus ensuring a nearly backlash free locked work position.



SMARTTURN: Encoder instead of mechanical switch mechanism

The new generation of rotary tables is optionally supplied with an inductive encoder and the autonomous control SmartTurn replacing the complex mechanical switch mechanisms and taking control of the table.

Advantages:

- Auto-adaptive system
- Extremely simple commissioning by executing the first motion cycle
- readjustment not required
- Integrated monitoring of the braking path and thus wear and tear of the brakes with alarm signal „Reline“ and emergency shut-down



Flexible Rotary Tables

Drive module for implementing flexible movement tasks by using freely programmable servo gear motors. The sequence of motions is determined by the motion profile of the servo gear motor. For this reason, output angle and acceleration can be freely selected and specifically adapted to each load case.

Based on their flexible application, the rotary tables of this design are particularly suitable for drive tasks, where the sequence of motions is to be adapted to the production process, e.g. due to new loads, a new position/end positions or directions of travel. A typical example is the production of different vehicles in a production line requiring flexible retooling in the pace of production.

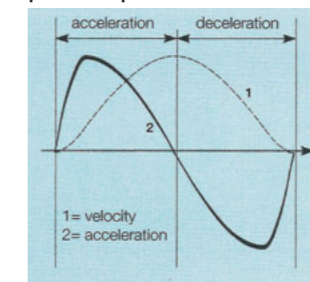

Heavy-duty Ring Tables

Rotary tables in accordance with the cam principle, are carried out in ring design due to their dimensions and diameters of more than 2 m. This results in the advantage of very flat basic constructions. The large centre diameter can be used either to arrange fixtures or positioning of handling equipment s.a. robots.

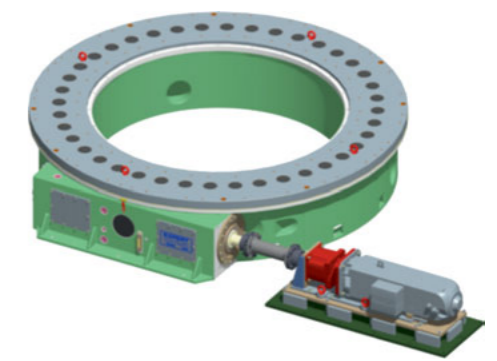

STANDARD ROTARY TABLES

Rotary tables with a system design reduced to the mechanical basic elements. The transmission of the rotary movement from the geared motor to the rotary table is ascertained by a geared ring or toothed belt. The constructionally simple and therefore economically priced systems are precision drives, additionally equipped with a positioning pin.



Example rotary table TXE with pinion/geared ring drive

COMPACT ROTARY TABLES

Key characteristics of the compact rotary tables are small dimensions and high precision. Typical fields of application are areas such as conveying technology, medical technology, packaging industry and therefore installations in which high-speed movements with precision are a decisive feature.



Compact Rotary Table Cube

INDEX DRIVE

The core element of a turning intermittent drive is an index drive. In addition to complete rotary drives, Expert-Tünkers and SOPAP also provide this index drive as a component to be integrated by the client into plant systems.

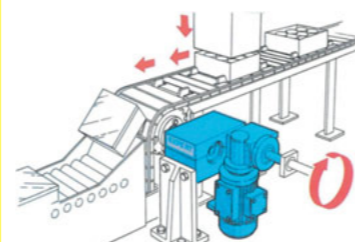

Application example index drive in conveying technology

Parallel-index Drive

Transformation of the stepping motion via disc cams, engaging into an output star equipped with yoke-type track rollers. Parallel arrangement of input and output shaft. In the stop position, the dwell period, a backlash-free and form-closed output positioning is ensured.

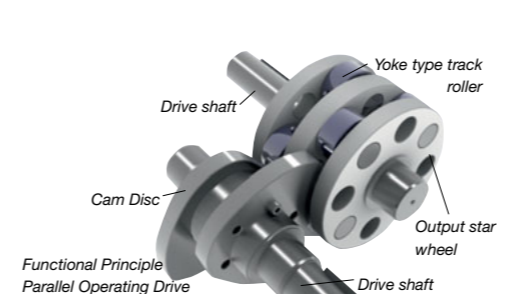

Functional Principle Parallel Operating Drive

Globoidal Index Drive

Realization of the stepping motion via a cam roll, engaging into the yoke-type track rollers of the output star. Vertical arrangement of input and output shaft. Nearly backlash-free mechanism, due to eccentric shaft bearing of the cam roll. The globoidal index drives are also available as rotary table with table plate.

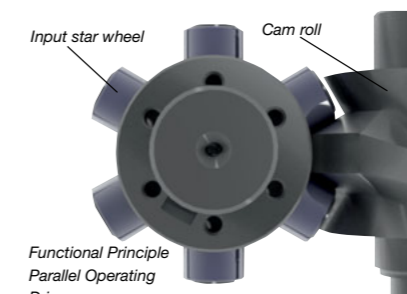

Functional Principle Parallel Operating Drive

MANUAL ROTARY TABLE

Rotary disc in robust bearing serving as mounting for a device to be manually rotated. Optional scope of delivery with manual shot pin, braking elements to be actuated via a foot switch and limit position switch.

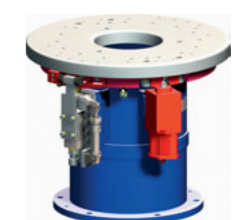

TURNING

Cam-driven Rotary Table

Cam-driven rotary table with fixed indexing EDX-Series



- Higher Torque due to multi-bolt principle with more compact dimensions
- Positioning via cam with low-backlash resting angle
- Use as table and trunnion drive

Type	Ø Disc in (mm)	Height in (mm)	Max. Torque in (Nm)
EDX 610	360	250	540
EDX 700	450	310	1100
EDX 810	560	360	2800
EDX 960	710	450	5000
EDX 1170	920	550	9000
EDX 1370	1120	620	15000
EDX 1600	1350	720	20000

Cam-driven Rotary Table, Flexible EDH-Series



- Flexible Standard Rotary Table
- Indexing and positioning via control
- Higher torque due to multi-bolt principle with more compact dimensions
- Use as table and trunnion drive

Type	Ø Disc in (mm)	Height in (mm)	Max. Torque in (Nm)
EDH 610	360	190	900
EDH 700	450	240	1500
EDH 810	560	280	4000
EDH 960	710	310	8000
EDH 1170	920	360	15000
EDH 1370	1120	420	25000
EDH 1600	1350	480	40000

Heavy-duty Ring Tables

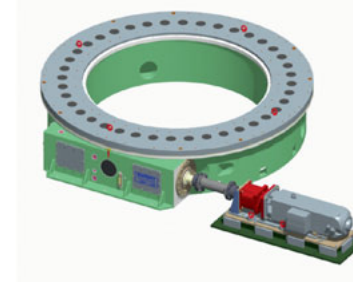

EDH-Series

- Flexible servo rotary table in ring design with cam diameters up to Ø 3 m
- Large central space also for rotation/robot position
- Robust cam technology for high load cycles

Type	Outer Ø Disc (A) in (mm)	Inner Ø (I) in (mm)	Height in (mm)	Max. Torque in (Nm)
EDH 2050	1800	900	480	60000
EDH 2550	2300	1300	450	127000
EDH 3250	3000	2000	600	145000

Compact Rotary Tables

Rotary Table Cube



C-Series

- Drive integrated in housing for optimum and nearly square mounting volume
- lower installation height
- inductive sensing cartridge for end position sensing
- 25% higher torque due to optimized gear ratio

Type	Ø Disc in (mm)	Height in (mm)	Max. Torque in (Nm)
C 100	120	150	27
C 300	215	341	197
C 500	320	465	1000

Globoidal Rotary Table

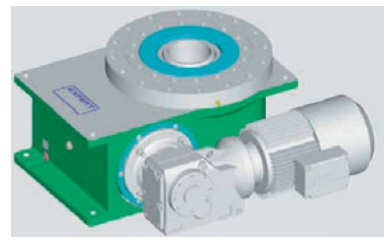

EGD-Series

- Backlash-free index drive for positioning tasks with hardened and ground globoidal cams and cam rollers.
- Quality bearing with high load ratings for precise synchronous operation

Type	Ø Disc in (mm)	Height in (mm)	Max. Torque in (Nm)
EGD80	80	126	65
EGD100	100	150	150
EGD125	125	190	400
EGD160	160	190	800
EGD200	200	290	1500
EGD250	250	355	2800

Compact Rotary Table



TS-Series

- Precision rotary table in compact design
- Fixed indexing with dwell period 45°, 60°, 90°, 180°
- Pre-loaded precision crossed roller bearings for high loads and precise synchronous operation
- Housing in aluminum design

Type	Ø Disc in (mm)	Height in (mm)	Max. Torque in (Nm)
TS 200	200	135	47
TS 300	300	191	197
TS 400	400	190	300

Standard Rotary Tables

Simplex Rotary Table

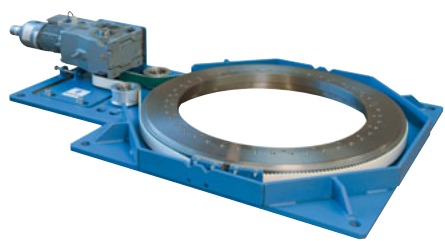

TXR-Series

- Rotary ring table with toothed belt drive
- extremely flat design
- option: precision shot pin

Type	Ø Torque in (mm)	Height in (mm)	Max. Torque in (Nm)
TXR 400	400	< 200	500
TXR 750	750	< 200	1000
TXR 1100	1100	< 200	3000

Simplex Rotary Table



TXE/TXI-Series

- Servo rotary table reduced to the essential
- robust crossed roller bearing
- Drive with servo gear motor and pinion / geared ring
- simple, robust design
- low height
- option: precision shot pin

Type	Ø Disc in (mm)	Height in (mm)	Max. Torque in (Nm)
TXE/TXI 400	400	500	830
TXE/TXI 750	750	700	1690
TXE/TXI 1100	1100	800	3250

Simplex Trunnion Drive

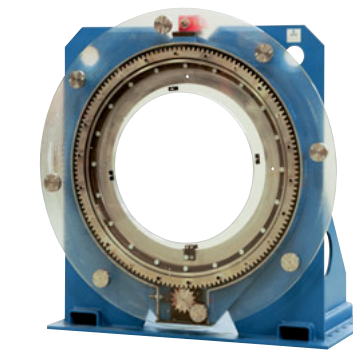

TXT-Series

- Servo rotary table for trunnion drive
- robust crossed roller bearing
- Drive with servo gear motor and pinion/geared ring
- simple, robust design
- option: precision shot pin

Type	Ø Torque in (mm)	Height in (mm)	Max. Torque in (Nm)
TXT 400	400	500	830
TXT 750	750	700	1690
TXT 1100	1100	800	3250

Index Drive

Parallel Index Drive



PA-Series

- Parallel Index Drive
- parallel arrangement of drive and output
- backlash-free in the locked area
- Use e.g. in indexing conveyor belts, systems with oscillating movements

Type	Max. permissible axial load Input shaft ABE (daN)	Max. permissible radial load Input shaft RBE (daN)	Height in (mm)	Max. Torque in (Nm)
65	16	65	130	113
80	37	140	190	218
105	55	200	200	450
130	80	250	250	912
165	250	728	320	1635
200	420	1190	390	2562
250	650	1940	490	4438
315	950	3270	620	9254

Globoidal Index Drive



EG-Series

- Index drive with vertical arrangement of input and output shaft
- backlash-free mechanism due to eccentric shaft bearing of the cam roller
- Application: oscillating movements with highest precision requirements

Type	True running on Ø k without load (mm)	Lateral running on Ø k without load (mm)	Static input torque mf1 (daNm)
50	0,02	0,02	0,5
63	0,02	0,02	0,8
80	0,02	0,02	1,5
100	0,02	0,02	2,2
125	0,02	0,02	3
160	0,02	0,02	4
200	0,02	0,02	5
250	0,02	0,02	6,5

Manual Rotary Table

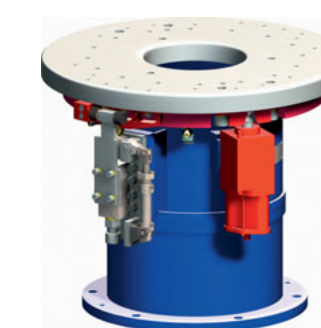

EDM-Series

- Rotary disc in robust bearing, serving as mounting for a device to be manually rotated.

- Option:
- manual shot pin
 - braking elements to be actuated via a foot switch
 - limit position switch

Type	Ø Disc in (mm)	Height in (mm)	Customer Load in (kg)
EDM 850	450	850	1000